



JOB NAME:	CONTRACTOR:
JOB LOCATION:	APPROVAL:
ENGINEER:	CONTRACTOR P.O.:
APPROVAL:	REPRESENTATIVE:

M8E0730-0* - M8E0731-0* - M8E0732-0*
(NPT) (SW) (BW)

730LL DIRECT MOUNT, 3-PC, 2-WAY STAINLESS STEEL, FULL PORT BALL VALVE IN NPT, SW OR BW W ELECTRIC ACTUATOR
SIZES 1/4" TO 4"

*001 12V AC/DC	*002 24V AC/DC	*003 100-240VAC
01 BATTERY BACKUP	*02* POSITIONER	*04* BAT. BACKUP W POS

SPECIFICATIONS

The M8E0730/M8E0731/M8E0732 series packages feature a stainless steel high performance three-piece full port, encapsulated bolt style, Class 900 [1/4"-2", Class 600 2 1/2"-4"] ball valve. The valve also incorporates an ISO 5211 direct mount pad with square stem. Further, the valve has high temperature TFM-4215 seats, conforms to ANSI 16.34, ANSI B1.20.1 Thread depths, NACE MRO 175, latch locking handle and an API 607 6th edition fire safe option. The Valbia VBM electric actuator has a rugged NEMA 4 die cast aluminum housing and features a raised or dome position indicator. In addition, the VBM series also incorporates dual voltage motors, two extra limit switches, a heater and thermostat, manual override, 1/2" conduit connections and a 75% duty cycle motor.

ACTUATOR FEATURES

- Dual Voltages
- CSA, UL approved
- 24V AC/DC and 100-240V AC
- ISO 5211 dual patterns
- 75% Duty Cycle
- High-Strength, Die Cast Aluminum Powder Coated Housing
- Temperature Range -4°F to 131°F
- NEMA 4 Housing
- Two Auxiliary Switches Standard
- Torque limiter standard
- 1/2" Conduit connections

VALVE FEATURES

- 3-piece CF8M body
- Class 900 sizes 1/4" to 2", Class 600 sizes 2-1/2" to 4"
- Stainless steel-2160 psi (1/4" to 2"), 1500 psi (2-1/2" to 4")
- ISO 5211 mounting pad w/ square stem
- Standard latch locking handle
- Conforms to ANSI 16.34, ANSI B1.20.1 thread depths, NACE MR0175
- Fire Safe to API 607-6th edition
- Grounded ball and stem
- Standard 316 stainless steel ball and stem
- Temperature range: +150° F to 500° F
- Working steam pressure to 250 psi

PRESSURE TEMPERATURE CHART FOR 730LL/731LL/732LL

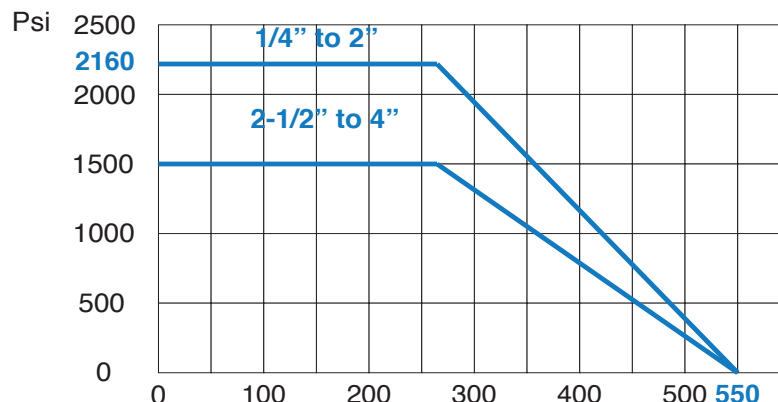

BILL OF MATERIALS FOR 730LL/731LL/732LL

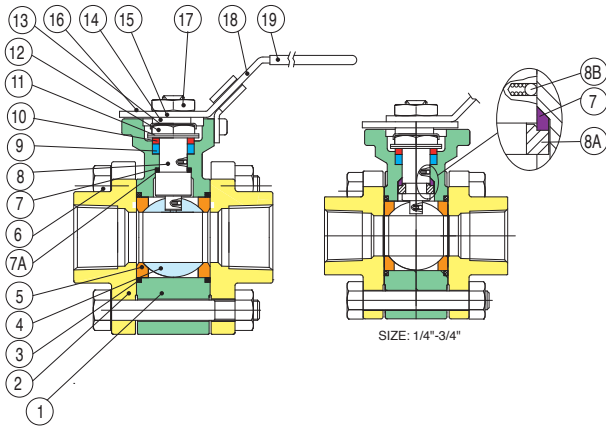

N POS	PART NAME	MATERIAL	N POS
1	BODY	CF8M	1
2	END CAP	CF8M	2
3	GASKET BODY	TFM	2
4	BALL	SS316	1
5	BALL SEATS	TFM-4215	2
6	BOLTS	SS304	*
7	THRUST WASHER	TFM	1
7A	THRUST WASHER	PEEK	1
8	STEM	SS316	1
8A	HALF SPLIT RING	SS316	1
8B	ANTI-STATIC	SS316	2

N POS	PART NAME	MATERIAL	N POS
9	STEM PACKING	TFM	1
10	GLAND WASHER	SS304	1
11	DISK WASHER	SS301	1
12	STEM NUT	SS304	1
13	NUT STOP	SS304	1
14	SPACE WASHER	SS304	1
15	PLATER	SS304	1
16	STOP IN	SS304	1
17	HANDLE NUT	SS304	1
18	HANDLE	SS304	1
19	HANDLE COVER	PLASTISOL	1

*VARIES WITH SIZE

DIMENSIONS

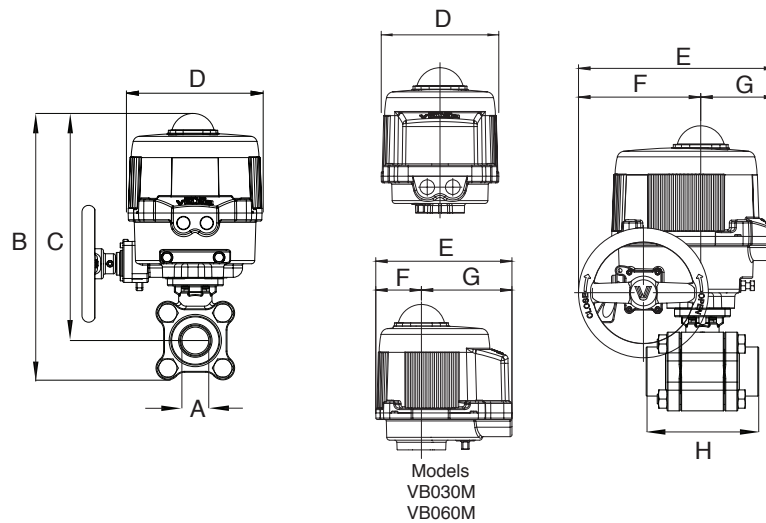

Size	A	B	C	D	E	F	G	H	ACT.
1/4"	0.25	10.45	9.64	6.34	7.36	2.48	4.88	2.64	VB030M
3/8"	0.38	10.45	9.64	6.34	7.36	2.48	4.88	2.64	VB030M
1/2"	0.50	10.57	9.72	6.34	7.36	2.48	4.88	2.64	VB030M
3/4"	0.75	10.85	9.91	6.34	7.36	2.48	4.88	2.99	VB030M
1"	1.00	11.19	10.15	6.34	7.36	2.48	4.88	3.35	VB030M
1-1/4"	1.25	12.20	11.10	6.93	7.76	2.48	5.28	3.66	VB060M
1-1/2"	1.50	12.65	11.41	6.93	7.76	2.48	5.28	4.13	VB060M
2"	2.00	14.81	13.22	10.63	10.48	6.50	3.98	4.80	VB110M
2-1/2"	2.50	15.67	13.81	10.63	10.48	6.50	3.98	6.10	VB190M
3"	3.00	16.51	14.40	10.83	10.98	7.24	3.74	6.89	VB270M
4"	4.00	20.72	18.17	15.50	-	-	-	8.03	EA360

ON/OFF WIRING DIAGRAM

12V AC/DC, 24V AC/DC & 100-240VAC

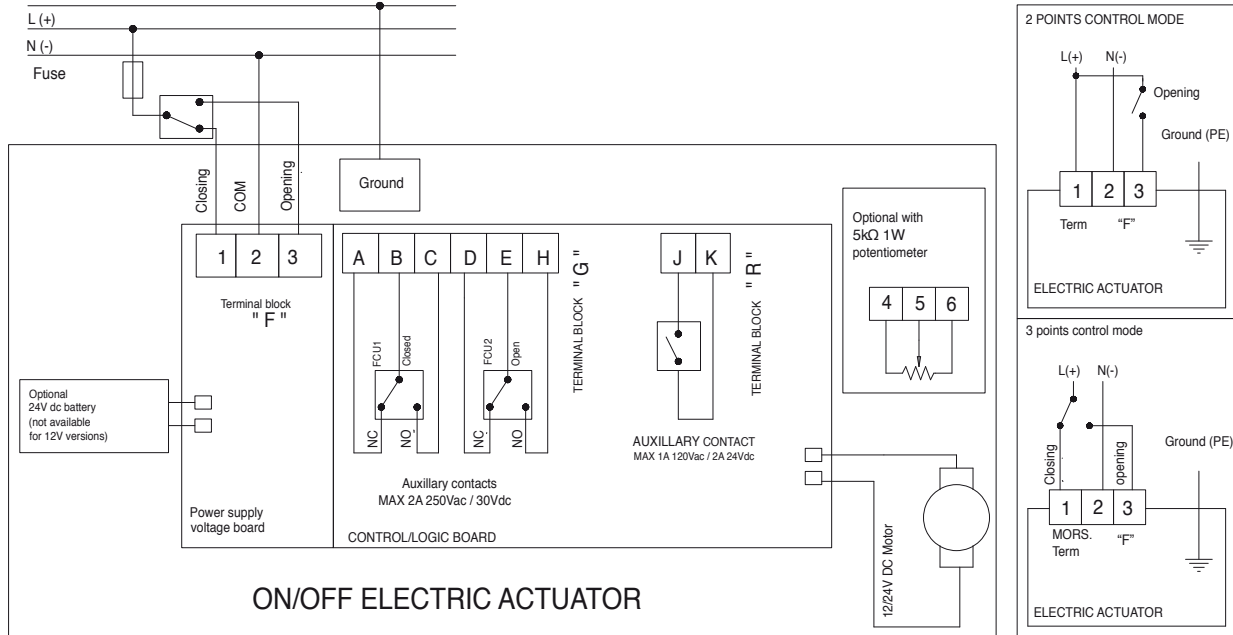

POSITIONER WIRING DIAGRAM

12V AC/DC, 24V AC/DC & 100-240VAC

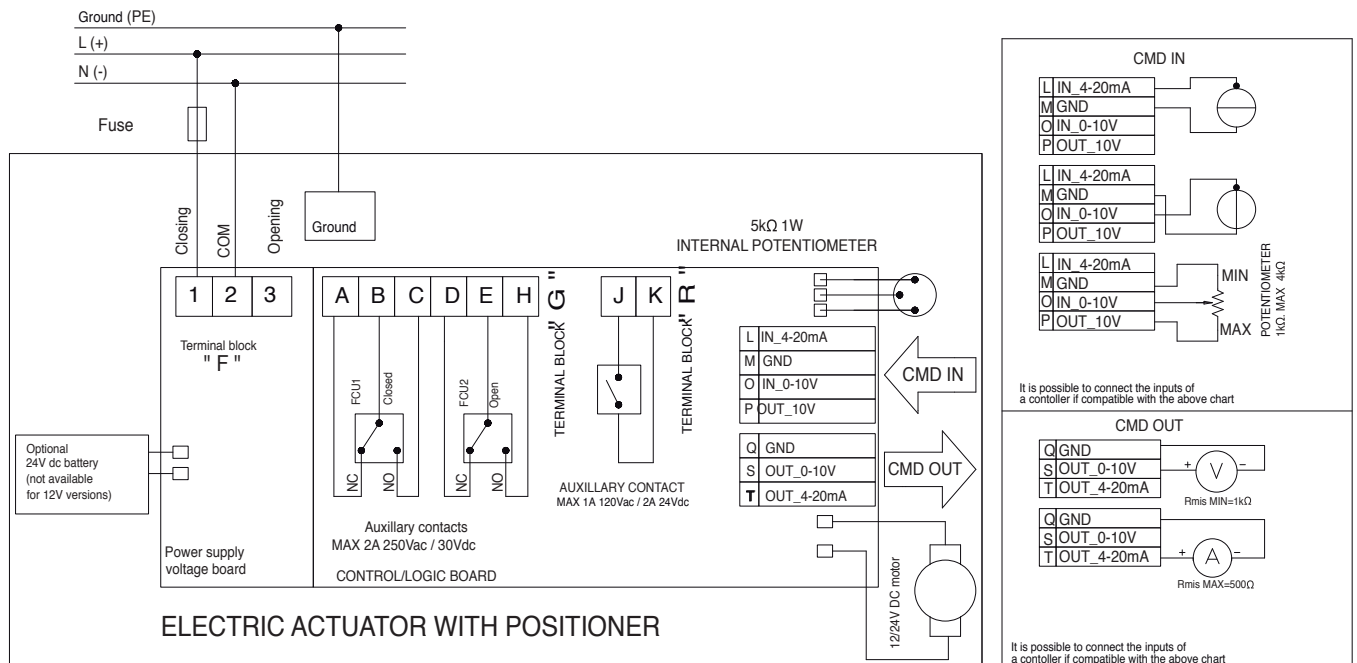

The power supply COM signal (pin "2" terminal block "F") cannot share the same electrical command ground signal (pin "GND" terminal block "CDM IN") or feedback ground signal (pin "GND" terminal block "CDM OUT").